

The isolator-amplifier W91 allows you to connect the digital LED signal with long wires when the driver is so far from the LEDs that there are disturbances in their operation. The device can be connected in various ways shown in the figure below. The isolator-amplifier provides electrical separation of the digital LED strip circuit from the cable to the controller, which significantly increases immunity to interference. Always place the device as close as possible to the LED strips.

VARIANT 1: POWER SUPPLY NEXT TO THE LED STRIP

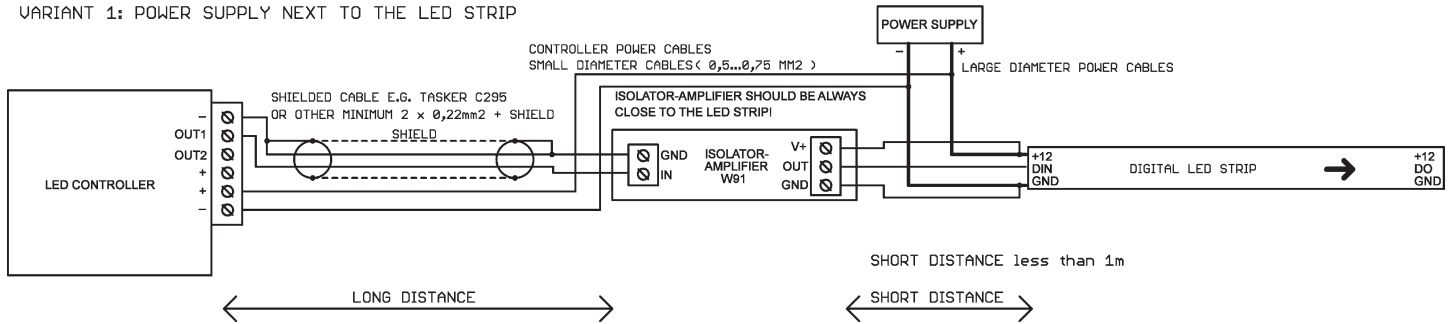

VARIANT 2: POWER SUPPLY NEXT TO THE CONTROLLER

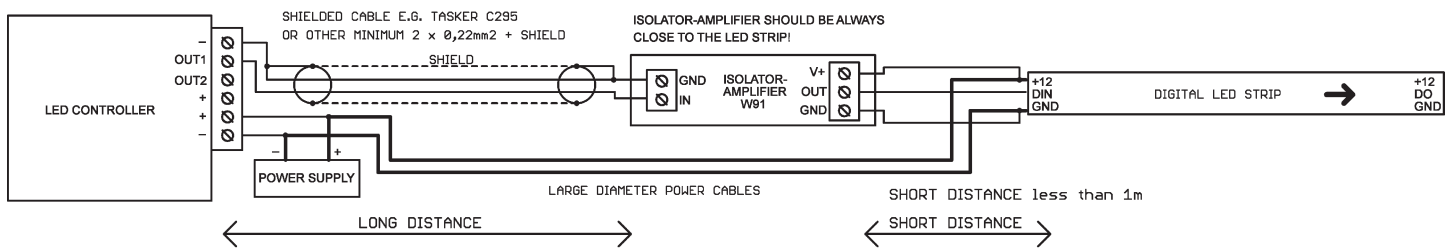

VARIANT 3: SEPARATE POWER SUPPLY FOR THE CONTROLLER (WALL ADAPTER)

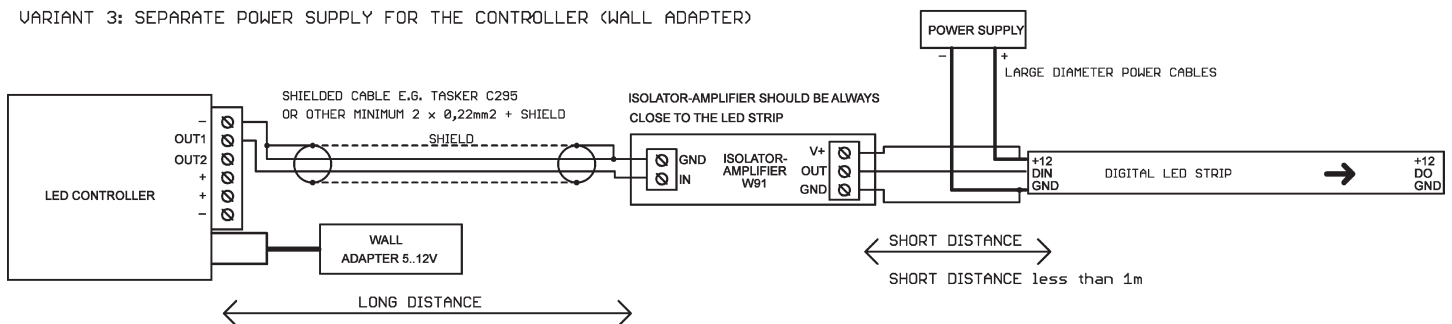

**WARNING**  
 Do not run control cables near any other cables. If not possible then shielded cable should be used (e.g. RG58CU or TASKER C295).  
 Connect the shield to ground (GND -).



**Device parameters:**

- supply voltage: 5..24V DC
- dimensions: 60 x 18 x 15mm

**Required operating conditions of the device:**

- ambient temperature from +1°C to +40°C - relative humidity from 30% to 75%
- installation of the device may only be carried out by a person with appropriate qualifications
- connect the device with the power supply disconnected
- operation of the device is not possible near sources of heat or harmful radiation and within the range of a strong electromagnetic field.
- clean the housing with a damp cloth, with the power supply disconnected - the device should be protected against contact with water or other liquids
- if the device has visible damage, it must not be connected to the power supply.

**Required device storage conditions:**

- only in closed rooms free of vapors and caustic agents.
- ambient temperature -30°C to +40°C, air humidity: 30% to 90% (non-condensing)

**Device Disposal:**

- the device must not be disposed of in ordinary waste containers. Unnecessary or used product should be delivered to special waste segregation centers run by municipal authorities.

The manufacturer does not bear any responsibility for possible consequences resulting from incorrect installation, improper use of the device, not reading the operating manual or self-repair attempts.